

APOLLO

DIECI APOLLO TELEHANDLER 2.5T / 5.8 M



25.6

DIECI
AUSTRALIA

PERFORMANCE

Machine model	APOLLO 25.6
Maximum capacity	2500 kg (5512 lb)
Maximum lifting height on wheels	5.78 m (19 ft)
Maximum horizontal extension on wheels	3.25 m (10.7 ft)
Fork swiveling angle	129°
Pull-out force	7600 daN (17085 lbf)
Towing force	4400 daN (9892 lbf)
Maximum climb angle	40%
Unladen weight	5100 kg (11244 lb)
Max speed (referred to wheels with maximum permitted diameter)	30 km/h (18.6 mph)

BOOM

Machine model	APOLLO 25.6
Lifting	7.8 s
Getting off the basket	4.1 s
Extension	6.1 s
Retraction	3.4 s
Forward swiveling	3.5 s
Reverse swiveling	2.2 s

ENGINE

Machine model	APOLLO 25.6
Brand	Kubota
Nominal power	55.4 kW (74 HP)
@rpm	2600 rpm
Operation	4-stroke
Injection	Mechanical
Number and arrangement of cylinders	4, Vertical in line
Displacement	3331 cm ³ (203 in ³)
Emission standards	Stage IIIA/Tier 3
Cooling system	Liquid
Intake	Turbo compressor

DIFFERENTIAL AXLES

Machine model	APOLLO 25.6
Axles types	2 steering, with 4 planetary reduction gears
Type of steering	4 wheels / transversal / 2 wheels
Front axle	Rigid
Rear axle	Swinging
Service brake	Oil bath on front axle
Park brake	Automatic spring applied hydraulic release

HYDRAULIC SYSTEM

Machine model	APOLLO 25.6
Hydraulic pump type	Gear pump for power steering and movements
Hydraulic pump capacity	80 L/min (21.1 gal/min)
Max. operating pressure	23.0 MPa (3336 psi)
Distributor control	4in1 proportional Joystick

REFUELING

Machine model	APOLLO 25.6
Hydraulic motor (total)	70.0 L (18.49 gal)
Diesel tank	80.0 L (21.13 gal)

TRANSMISSION

Machine model	APOLLO 25.6
Transmission type	Single speed Hydrostatic transmission with variable displacement pump
Hydraulic motor	Hydrostatic with continuous automatic adjustment
Reversal	Electro-Hydraulic
Inching	With electronic pedal for controlled forward movement

TYRES

Machine model	APOLLO 25.6
Standard tyres	12x16.5"

DIMENSIONS

Machine model	APOLLO 25.6
A	270 mm (10.6 in)
B	985 mm (38.8 in)
C	2350 mm (92.5 in)
D	765 mm (30.1 in)
F	3535 mm (139.2 in)
G	4125 mm (162.4 in)
H	1950 mm (76.8 in)
I	1850 mm (72.8 in)
L	1500 mm (59.1 in)
M	1850 mm (72.8 in)
P	1460 mm (57.5 in)
Q	3555 mm (140 in)
S	1433 mm (56.4 in)
T	200 mm (7.9 in)

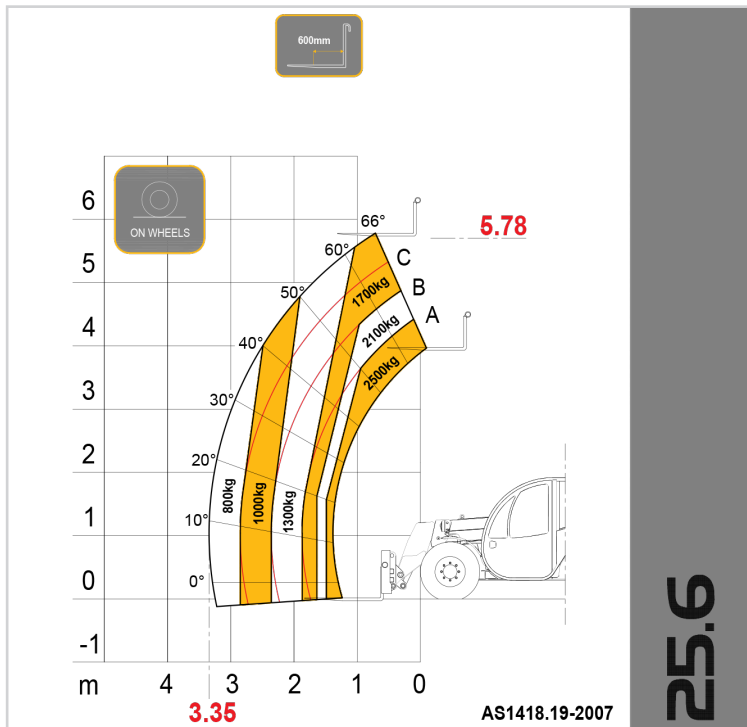
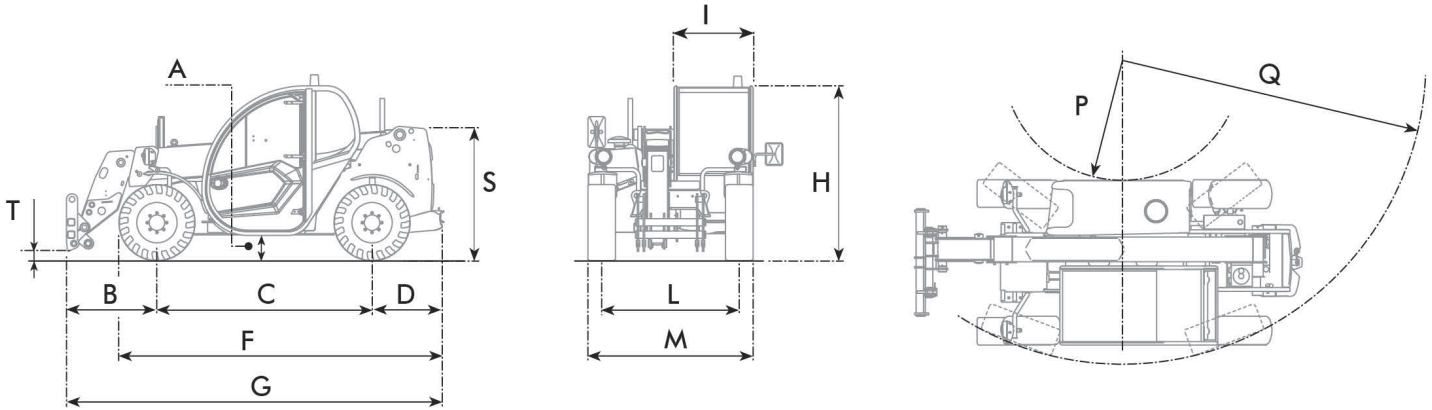



Distributed by Dieci Australia and their network of authorised dealers.

25 Garner Place, Ingleburn NSW 2565
www.dieciaustralia.com.au | info@dieciaustralia.com.au
Tel. +61 2 8795 4555

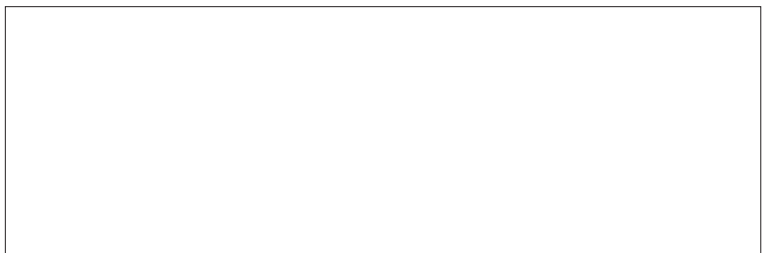

Illustrations and photos show the standard international models and may or may not include optional equipment, accessories, customer installed or modified parts, optional parts and all standard equipment with some differences in colour and features. Machine specifications are subject to change without notice and additional load charts and machine or attachment specifications may be available on request. Please refer to the operators manual for correct machine and attachment operation.

Printed in Australia SKT Apollo EXTRA-EC-AU | 1.5 2019