



ES12-12CS ES15-15CS Electric Stacker 1.2/1.5t

Counterbalance Stackers, Better for Non-standardized Pallets.
Electric Steering System Makes the Operations Much Easier.

EP EQUIPMENT CO.,LTD
www.ep-ep.com



FEATURE



Performance

- The innovative AC system offers strong power, accurate control, excellent performance.
- High strength vertical gearbox, longer working life.
- Low-noise but durable hydraulic unit, good quality cylinder as well as hose ensure the high reliability of hydraulic system.
- AMP connector and durable electric wires greatly reduce malfunctions of components.
- High strength chassis enhances the reliability and durability of the truck.
- Standard featured tilt mast cylinder design and controller monitoring the tilt speed smoothly and ensures safe performance.
- Heavy duty load wheel ensures stability.
- Compact design with small turning radius requirements.

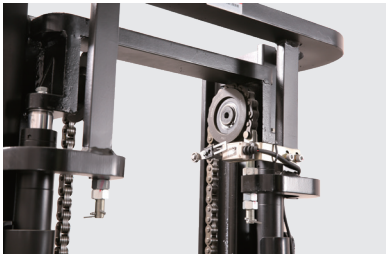

Safety

- Safe hydraulic system design prevents mast from falling down abruptly when hydraulic pipeline cuts off.
- Emergency reverse belly button protects the operator from getting hurt.
- Emergency disconnecter will cut off power source to avoid accident when truck goes out of control.
- Multiple lifting limit protection ensures safety.
- Automatic switch to lower speed when the fork reaches its setting height.
- Anti-rolling back brake keeps the truck from skidding down when truck is out of control or travelling on ramp.
- Dual-monitoring power steering.

Operation

- With the new design of ergonomical tiller head, all buttons can be reached conveniently & comfortably.
- Foldable platform reduces vibration which makes operator feel more comfortable.
- When platform folded, truck can work at low speed in smaller space.
- Adjustable forks, suitable for complicated pallets or cargos.
- Tilting as standard configuration, make operation easier.
- Side-open battery design for easy battery replacement and various applications.
- Electric power steering, smooth & comfortable (EPS).

Maintenance

- AC traction motor, maintenance free.
- Hour meter and battery indicator will remind the operator to recharge the battery.
- Easily remove the back cover by only losing four bolts; Access to all key components for inspection, maintenance and replacement.
- Press-on load wheel reduces the maintenance cost.
- Vertical motor makes the inspection & service much more convenient.
- Control system allows easy trouble-shooting.
- Mast and chassis are assembled together, easy for maintenance.
- Low voltage cut off setting protects batteries.

Electric Stacker 1.2/1.5t ES12-12CS/ES15-15CS

Distinguishing mark					
1.1	Manufacturer			EP	EP
1.2	Model designation			ES12-12CS	ES15-15CS
1.3	Drive unit			Electrics	Electrics
1.4	Operator type			pedestrian	standing
1.5	rated capacity	Q	kg	1200	1500
1.6	Load center distance	c	mm	500	600
1.8	Load distance, centre of drive axle to fork	x	mm	208	215
1.9	Wheelbase	y	mm	1244	1355
Weight					
2.1	Service weight (include battery)		kg	1860	2420
2.2	Axle loading, laden driving side/loading side		kg	375/2685	510/3410
2.3	Axle loading, unladen driving side/loading side		kg	1060/800	1430/990
Types, Chassis					
3.1	Tyre type Driving wheels/Loading wheels			polyurethane/ polyurethane	PU/PU
3.2	Tyre size, driving wheels (diameter×width)		mm	Φ230× 75	Φ260×105
3.3	Tyre size, loading wheels (diameter×width)		mm	Φ254×102	Φ254×102
3.4	Tyre size, caster wheels (diameter×width)		mm	—	—
3.5	Wheels, number driving, caster/loading (x=drive wheels)		mm	1x, 0/2	1x, 0/2
3.6	Track width, front, driving side	b ₁₀	mm	787	787
3.7	Track width, rear, loading side	b ₁₁	mm	—	—
Dimensions					
4.1	Tilt of mast/fork carriage forward/backward	α/β	°	1.5/6	1.5/6
4.2	Height, mast lowered	h ₁	mm	2110	2118
4.3	Free lift	h ₂	mm	150	150
4.4	Lift height	h ₃	mm	3210	3140
4.5	Height, mast extended	h ₄	mm	4185	4115
4.9	Height drawbar in driving position min./max.	h ₁₄	mm	1013/1402	1013/1402
4.10	Height of wheel arms	h ₈	mm	282	282
4.15	Lowered height	h ₁₃	mm	60	60
4.19	Overall length	l ₁	mm	2835	2985
4.20	Length to face of forks	l ₂	mm	1738	1915
4.21	Overall width	b ₁ / b ₂	mm	850/900	850/900
4.22	Fork dimensions	s/ e/ l	mm	40/100/1070	40/100/1070
4.24	Fork carriage width	b ₃	mm	800	800
4.25	Outside width of the forks	b ₅	mm	200-760	200-760
4.31	Ground clearance, laden, below mast	m ₁	mm	78	78
4.32	Ground clearance, center of wheelbase	m ₂	mm	70	70
4.34.1	Aisle width for pallets 1000 × 1200 crossways	Ast	mm	3085	3270
4.34.2	Aisle width for pallets 800 × 1200 lengthways	Ast	mm	3200	3385
4.35	Turning radius	Wa	mm	1535	1715
Performance data					
5.1	Travel speed, laden/ unladen		km/ h	5.5/6.0	4.65
5.2	Lifting speed, laden/ unladen		m/ s	0.127/0.23	0.12/0.17
5.3	Lowering speed, laden/ unladen		m/ s	0.26/0.2	0.13/0.1
5.8	Max. gradeability, laden/unladen		%	5.0/8.0	5.0/8.0
5.10	Service brake type			Electromagnetic	Electromagnetic
Electric-engine					
6.1	Drive motor rating S2 60 min		kW	1.5	4
6.2	Lift motor rating at S3 15%		kW	2.2	3
6.3	The maximum allowed size battery		mm	810/230/open	810/330/open
6.4	Battery voltage/nominal capacity K5		V/ Ah	24/210	24/280
6.5	Battery weight		kg	190	320
Addition data					
8.1	Type of drive unit			AC	AC
10.5	Steering type			Electronic	Electronic
10.7	Sound pressure level at the driver's ear		dB(A)	74	74

If there are improvements of technical parameters or configurations, no further notice will be given.
The diagram shown may contain non-standard configurations.

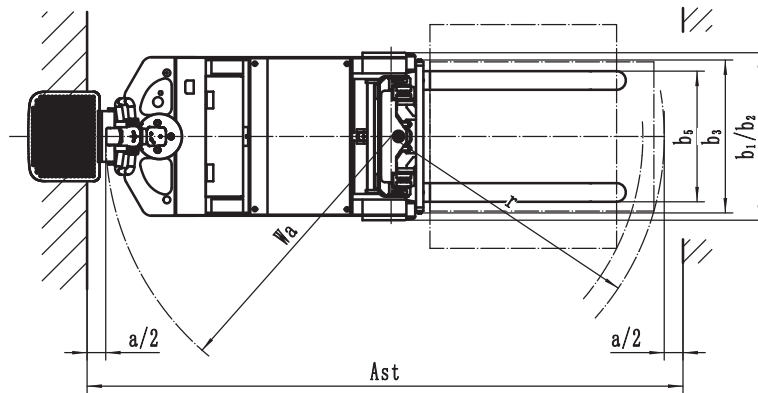
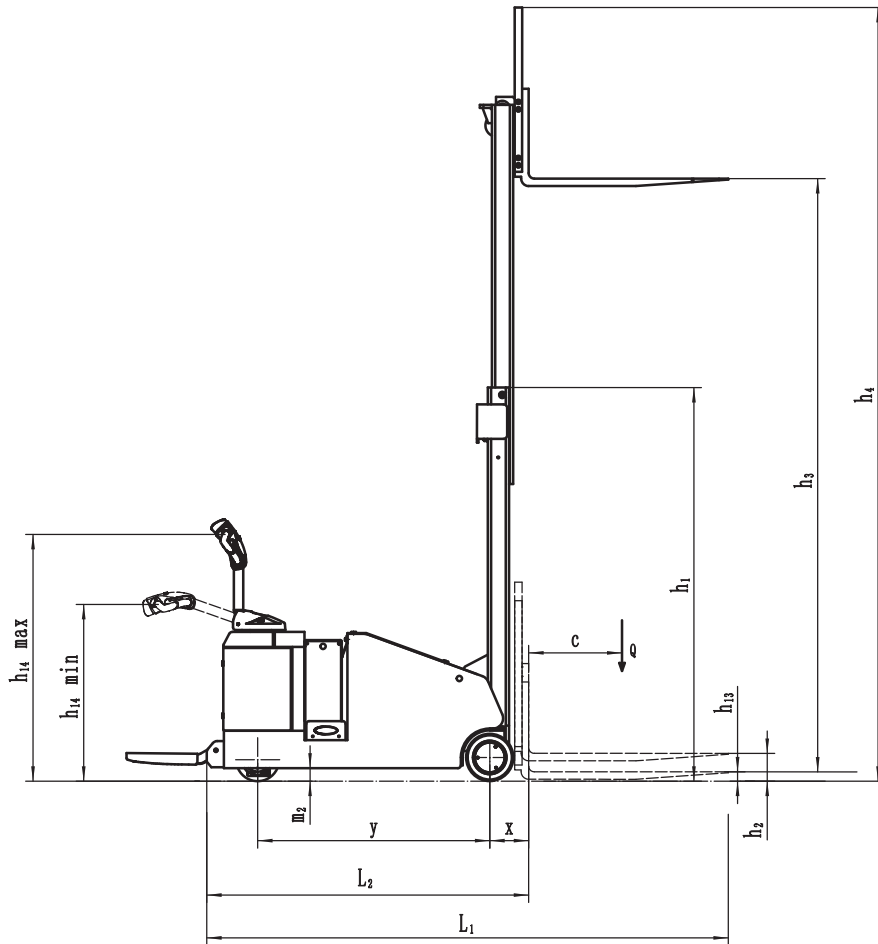

RATED CAPACITIES GRAPH

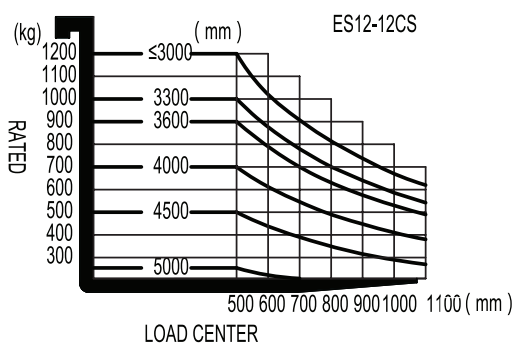

RATED CAPACITIES GRAPH

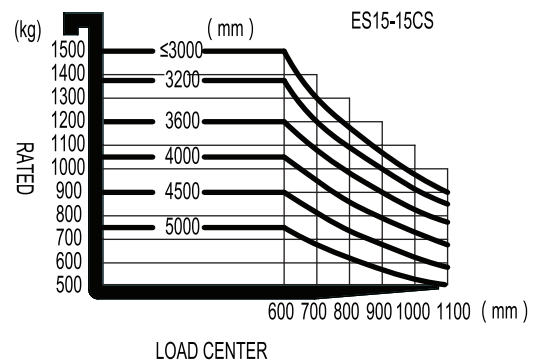

Mast Option

ES12-12CS

Lift h3+h13 (mm)	mast types	Lowered mast height h1 (mm)	Free lift h2 (mm)	Extended mast height h4 (mm)
2470	Duplex ZT	1710	150	3385
2670		1810	150	3585
2970		1960	150	3885
3270		2110	150	4185
3570		2260	150	4485
3870		2410	150	4785
4000	Triplex DZ	1822	904	4915
4500		2022	1104	5415

ES15-15CS

Lift h3+h13 (mm)	mast types	Lowered mast height h1 (mm)	Free lift h2 (mm)	Extended mast height h4 (mm)
2640	Duplex ZT	1838	150	3555
3000		2018	150	3915
3200		2118	150	4115
3590		2303	150	4505
4000	Triplex DZ	1822	907	4915
4500		2022	1107	5415
5000		2187	1272	5915

Option

Options		ES12-12CS	ES15-15CS
3	Fork length	●1070	●1070
4	Fork width	●200-760(Adjustable)	●200-760(Adjustable)
10	Driving wheel	●PU	●PU
11	Balance wheel	—	—
15	cold storage	○	○
16	Mast screen	—	—
17	Battery indicator with hour meter	●	●
18	Battery indicator without hour meter	○	○
19	Battery capacity	○280AH/224AH (Maintenance-free)	○360AH
20	Lateral change battery	○	○
22	Water auto-filling system	○	○
25	Vertical handler working	—	—
26	Proportional lifting	○	○
27	Height limitation	●	●
30	Side shift	○	○
31	half speed function in turning	●	●
32	Guard arm	—	—

Note: ● standard ○ option — NA