

Type FJL2.5 Fixed Jib (Long)

The type FJL2.5 Fixed Jib (Long) is designed as an affordable general purpose Jib with a 3.5 metre reach when fully extended. This slip-on Forklift attachment is held to the Forklift by a safety chain. The Jibs overall length when closed is 2.1 metres.

Available in either galvanised or painted enamel finishes.

SPECIFICATIONS:

- Safe Working Load (SWL) 2500kg Max.
- Unit Weight 130kg
- Load Centre 950mm
- Pocket Size 165 x 65
- Pocket Centres 250 mm
- Horizontal C of G 1400mm
- Vertical C of G 50mm

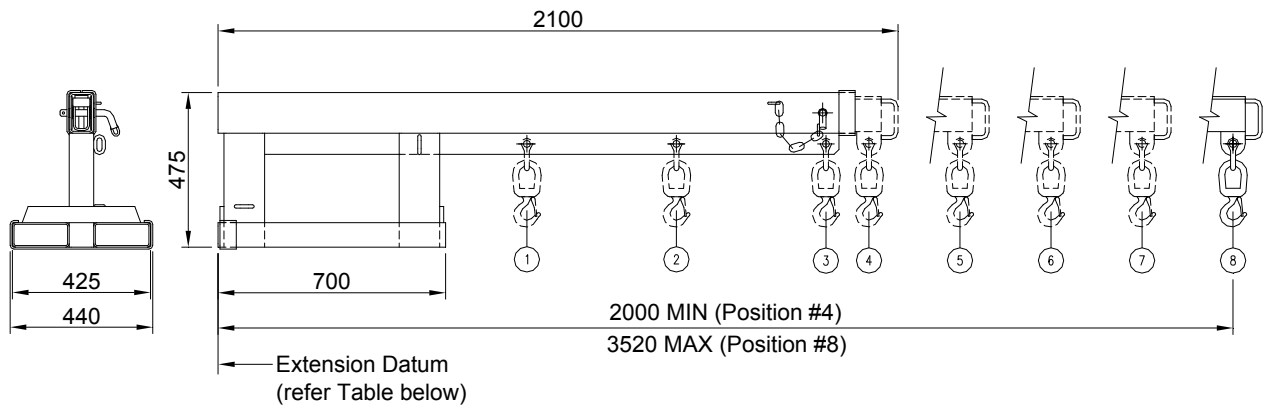
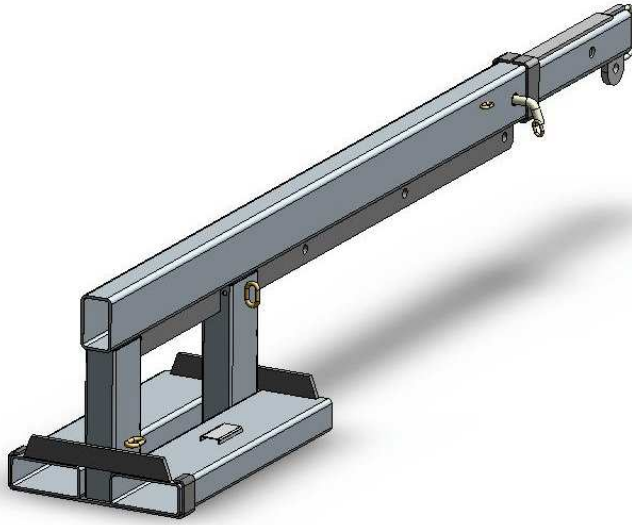

SAFE WORKING LOADS (SWL) PER POSITION

POSITION	1	2	3	4	5	6	7	8
EXTENSION (mm)	950	1410	1870	2000	2380	2760	3140	3520
SWL (kg)	2500	2500	1900	1650	1250	650	380	240