

SJIII 4740 ELECTRIC SCISSOR LIFT

Dimensions	SJIII 4740
A Work Height	13.80 m
B Raised Platform Height	11.80 m
C Lowered Platform Height	1.37 m
D Overall Width	1.19 m
E Overall Length (Platform Retracted)	2.40 m
F Stowed Height (Rails Up)	2.48 m
G Stowed Height (Rails Down)	2.21 m
H Platform Width (Inside Railing)	1.06 m
I Platform Inside Length (Retracted)	2.19 m

Specifications	SJIII 4740
Extension Deck (Roll Out)	0.90 m
Ground Clearance (Pothole Raised)	8.10 cm
Ground Clearance (Pothole Deployed)	1.90 cm
Wheelbase	1.85 m
Weight	2,970 kg
Gradeability	25%
Turning Radius (Inside)	0.54 m
Turning Radius (Outside)	2.58 m
Lift Time (With Rated Load)	71 sec
Lowered Time (With Rated Load)	41 sec
Drive Speed (Stowed)	3.2 km/h
Drive Speed (Raised)	1.0 km/h
Maximum Drive Height	Full Height
Capacity (Overall)	350 kg
Maximum # of Persons (Indoor/Outdoor)	3/0
Tyre Type	Solid, N/M
Tyre Size	16 x 5 x 12

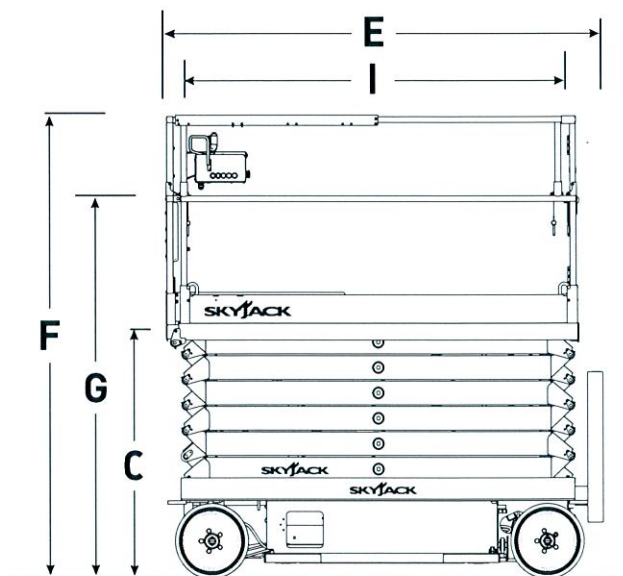
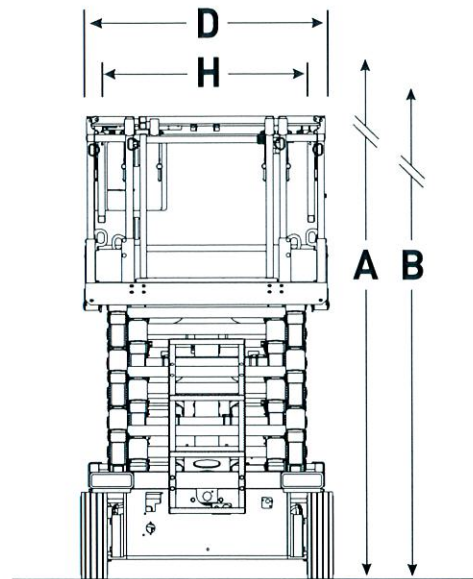

Skyjack Australia Pty Ltd
 4 Coates Place
 Wetherill Park
 New South Wales, 2164
 Tel: +61 (0) 2878 63200
 Fax: +61 (0) 2878 63222
 Email: jcranmer@skyjack.com

www.skyjack.com

This brochure is for illustrative purpose only and based on the latest information at the time of printing. Skyjack Inc. reserves the right to make changes at any time, without notice, to specifications, standard and optional equipment. Consult the Operating Maintenance and Parts Manuals for proper procedures. AS marked platforms are in conformance to Standard AS/NZS 1418.10:2011.